

External Dimensions (mm)

SM-5100B

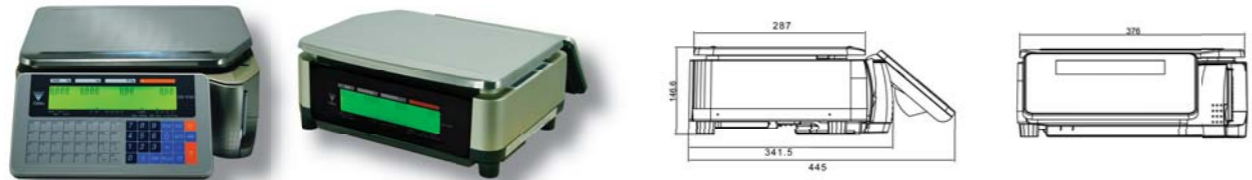

SM-5100P

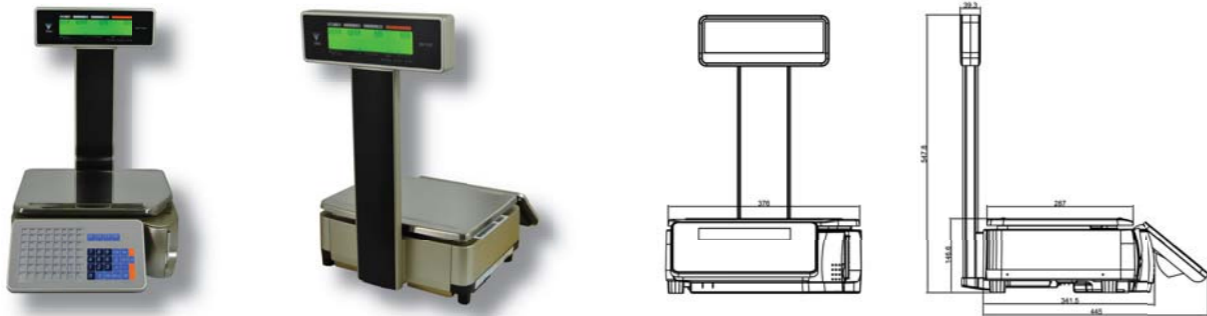

SM-5100EV

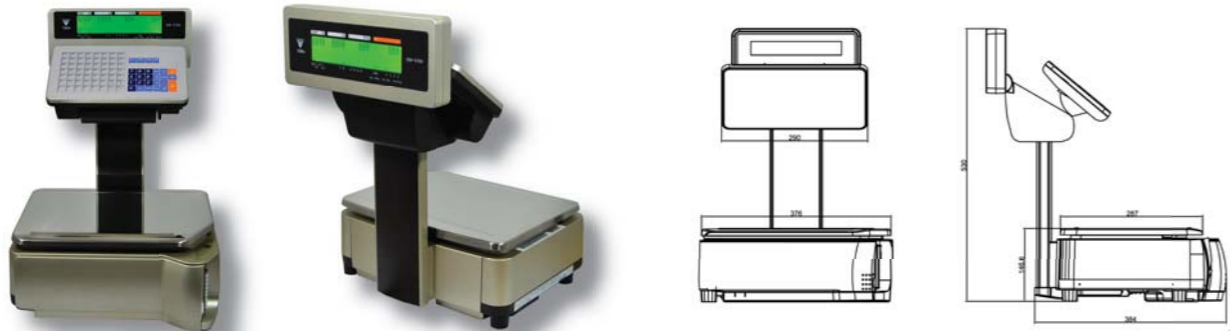

SM-5100

Scale Receipt Printer

Powerful Features in a Compact Scale Printer



SM-5100B



SM-5100P



SM-5100EV

Basic Specifications

Model	SM-5100B	SM-5100P	SM-5100EV
Capacity	Max 3 / 6 kg	Max 6 / 15 kg	Max 15 / 30 kg
Interval	e = 1 / 2 g	e = 2 / 5 g	e = 5 / 10 g
Display	32 x 202 Full Dot Matrix LCD with Back-Light (Top Row : 5 x 10 Dots / Character , Bottom Row : 7 x 12 Dots / Character)		
Number of Preset Keys	32	56	56
Memory Capacity	1MB (Standard) 2MB (Option)		
Display Resolution	1 / 3,000		
Paper Width	Max 60 mm (Label) 60 mm (Receipt)		
Printing Speed	80 mm/sec (Label) 105 mm/sec (Receipt)		
Label Size	Maximum 60 (W) x 220 (L) mm		
Power Source	AC 100 / 110 / 220 / 230 / 240 Volts (50 / 60 Hz.)		
Operating Temperature	-10 °C to +40 °C		
Standard Interface	RS232C, Ethernet, Cash Drawer I/F		
Optional Interface	Wireless LAN I/F (IEEE 802.11b/g)		
Dimensions (mm) (W) x (D) x (H)	376 x 445 x 146.6	376 x 445 x 547.8	376 x 384 x 530

*Specifications are subject to change without prior notice.

SHANGHAI TERAOKA ELECTRONIC CO., LTD.

TINGLIN INDUSTRY DEVELOPMENTAL ZONE,
JINSHAN COUNTY, SHANGHAI 201505

TEL: +86-21-57234888

FAX: +86-21-57233049

http://www.digisystem.com

Searching for
a New Balance

SM-5100

versatile scale printer for store operations

Weigh quickly, print rapidly to increase throughput.

SM-5100 designed to meet the weighing needs of any retail store.

This Series provides the best value for your store's operation.

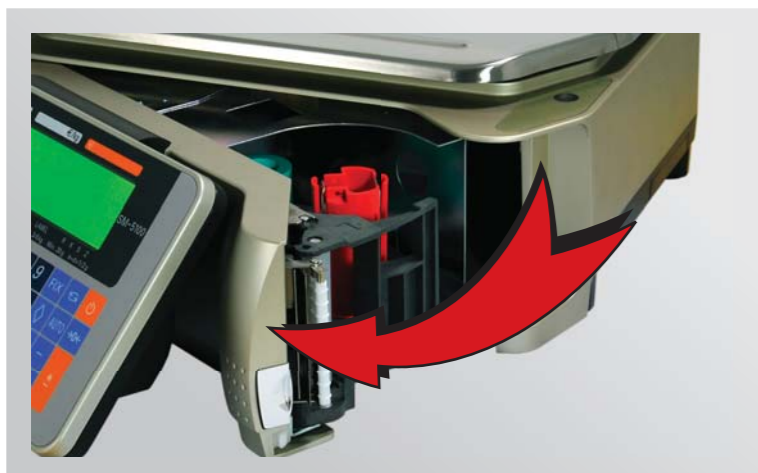

Easy to Change Label & Receipt

Changing the thermal paper roll is easy through the large opening in the scale housing which enables quick loading of the label or receipt roll.

Compact Design for Save Space

Effective use of sales space, shorten the distance of communication with customer.

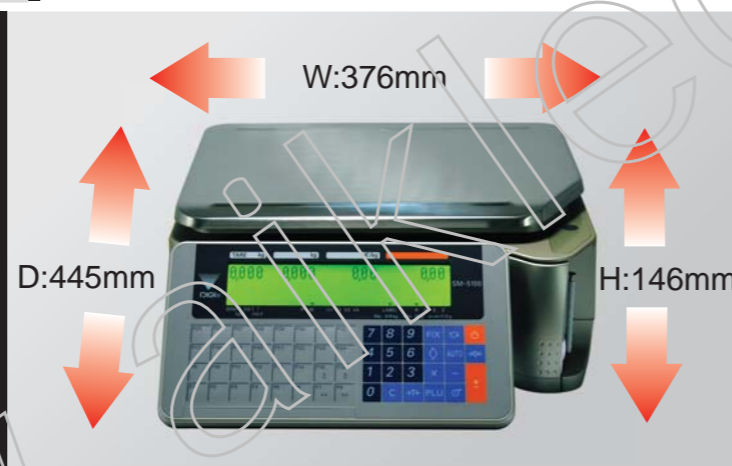

Free Angle of Operator Panel and Water Resistant Keyboard

Free angle adjustment of operator panel for easy operation. Water resistant membrane keyboard stands up to frequent use.



Large & Clear Display

Customer and operators can easily read the bright alpha-numeric LCD with back-light.

Large characters display the product name or scroll messages for promotions or store specials.

POWERFUL COMMUNICATION CAPABILITIES STANDARD

- Through the standard Ethernet or RS-232 interface, inter-scale and store controller communication is readily available.
- With the Wireless LAN network interface, scale installation locations can quickly change without added costs. (wireless network card is optional.)
- Quick weight stabilization and fast label / receipt printing allows the operator to serve more customers and increase volume of the operation.
- Barcode Scanner can also be connected to enhance the operation.
- Nutritional facts and traceability information can be easily designed and printed for better customer service.